

Technology
you can
rely on

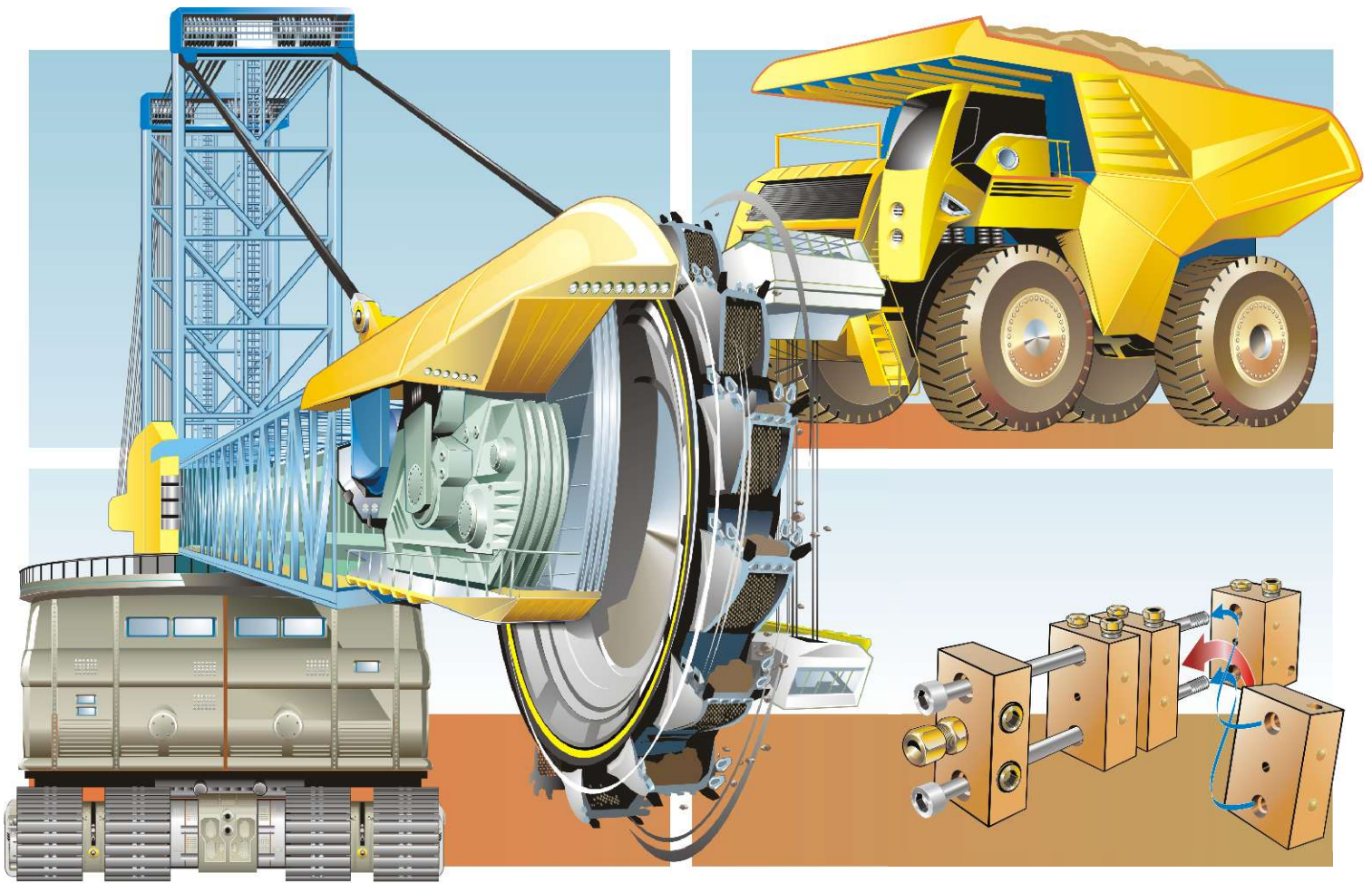

Central Lubrication Systems for Mining Machines



The progressive system

The progressive system supplies the lubrication points in a fixed order. It can be operated optionally with oil or grease up to NLGI 2.

The progressive distributor works consecutively (progressive). Only after the first lube point has received the right lubricant quantity, the distributor continues running and delivers the next one.

The progressive system can be monitored easily and offers various extension possibilities.

BEKA progressive distributors distinguish themselves by modular flexibility instead of rigid block design. Caused by the tried-and-tested disc design, BEKA progressive distributors can be adapted to the individual demands like number of lube points or output at any time.



BEKA SX-D distributor box

The individual sectional system

The sectional system is an extended progressive system. Large plants with a high number of lubrication points are divided into sections which are supplied by a pump station. The single sections can be controlled and monitored individually. Even differently stressed areas can be supplied as required.

The sectional system can be extended quasi without limits and offers the possibility to monitor each single lubrication point.



BEKA protective chamber: The whole lubrication technology is protected against dirt and damages.



The single line system

The lubrication pump of the single line system delivers the lubricant to the distributors. The line system can be branched as required. The single line system can be controlled by integrated or external control systems.

The single line system is characterized by easy installation, operation and maintenance and can be extended as required. It is tried-and-tested in large numbers all over the world.



BEKA injectors

The dual line system

The dual line system is the classical solution for large plants. The lubricant can be transported over wide distances. The number of connected lubrication points has nearly no limits.

Dual line combination consisting of switch-over unit, distributors and differential pressure switch.

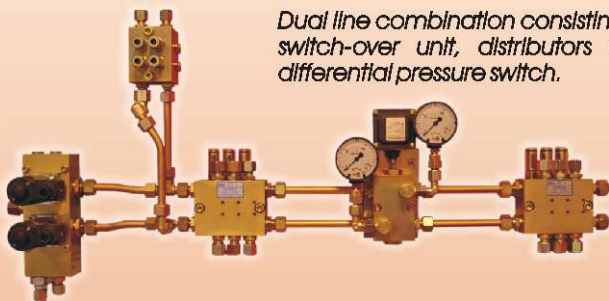

Lubrication pumps in all sizes

The BEKA product range offers an enormous diversity of lubrication pumps:

- With electrical, hydraulic or pneumatical drive
- With a wide range of reservoir capacities
- Barrel pumps with electrical, hydraulic or pneumatical drive
- Powerful filling pumps

All BEKA pumps distinguish themselves with highest quality and operational reliability. They are tried-and-tested all over the world.



Barrel pump station type HFP

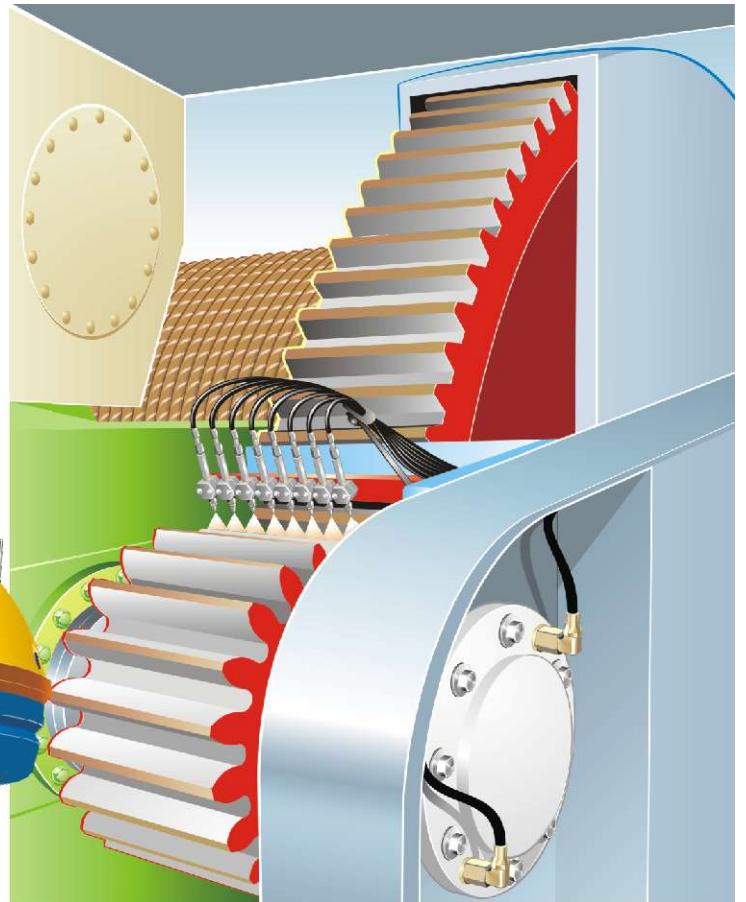

Gear rim lubrication with lubrication pinion

The lubrication system with lubrication pinion is a special solution for the lubricant supply of gear rims. Lubricant directly comes out of holes in the toothed flank of the lubrication pinion.

Caused by the design of the pinion, lubrication happens only during intermeshing. The lubrication pinion is suitable for grease up to NLGI 2.

Advantages of the lubrication pinion:

- Rugged design, made of aluminium
- Adapted to the module of the gear wheel
- Reliable lubrication of the contact zone
- Suitable for grease up to NLGI class 2

The lubricating pinion delivers lubricant only during intermeshing. This cares for reliable greasing of the highly loaded tooth faces.



The spray lubrication system

The spray lubrication system represents the clean and innovative alternative to conventional gear rim lubrication. The lubricant is transported and splitted by compressed air and then divided by patented mixing distributors. Spray nozzles care for the lubricant apply onto the tooth faces.

This highly-efficient and non-contacting technology even works with very little rotary motions. Caused by the special technology, spray lubrication is even suitable for lubricants with high solids content.

Advantages of the spray lubrication system:

- Precise lubricant apply onto the tooth faces
- Only the friction areas are lubricated
- Very low lubricant consumption
- No over-lubrication

Spray lubrication system installed at a winch drive

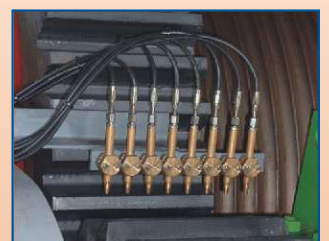



Excavator SchRs 1320/4x30
653 lubrication points

3x hydraulic barrel pump (200 kg) with dual line and sectional system
2x high pressure pump FKGM-EP (8 kg) with progressive system
1x high pressure pump F-Super3 (48 kg) with progressive system
6x spray lubrication system

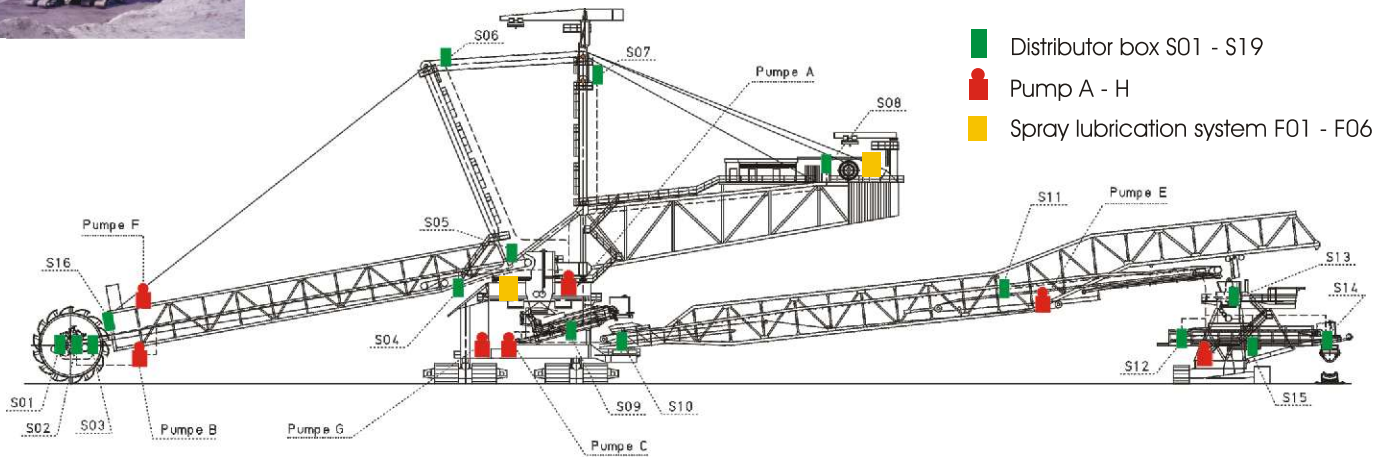

Excavator K2000
1005 lubrication points

5x hydraulic barrel pump (200 kg) with sectional system
1x high pressure pump F-Super3 (48 kg) with progressive system
13x spray lubrication system

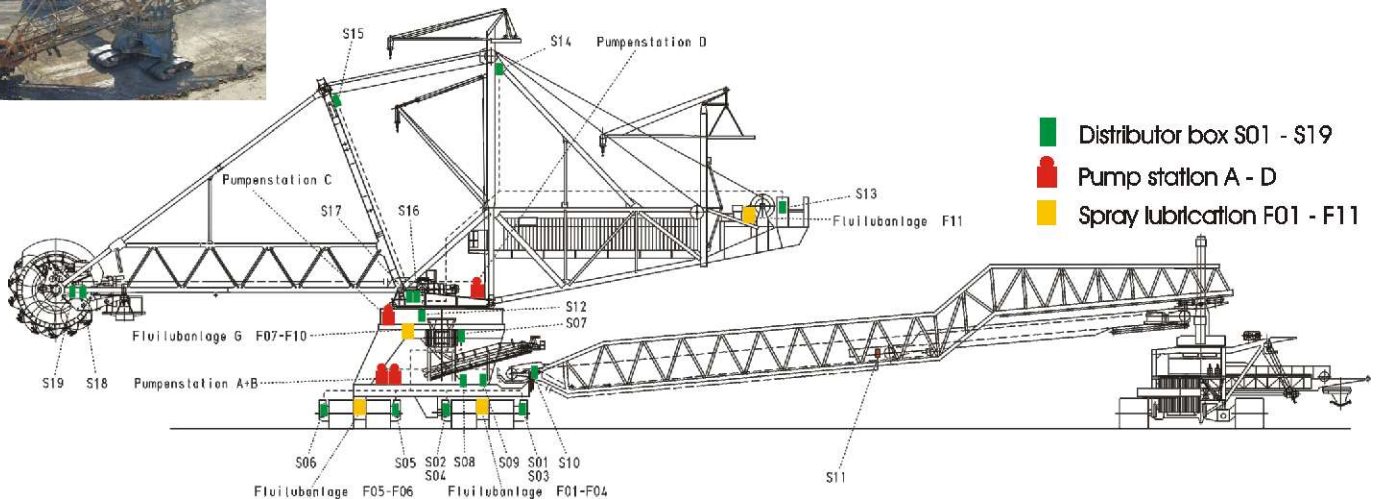

Spreader ZPDH 6300.1-CZ
342 lubrication points

3x hydraulic barrel pump (200 kg) with dual line and sectional system
1x high pressure pump F-Super3 (48 kg) with progressive system
1x high pressure pump F-Super3 (48 kg) with pinion lubrication
2x spray lubrication system

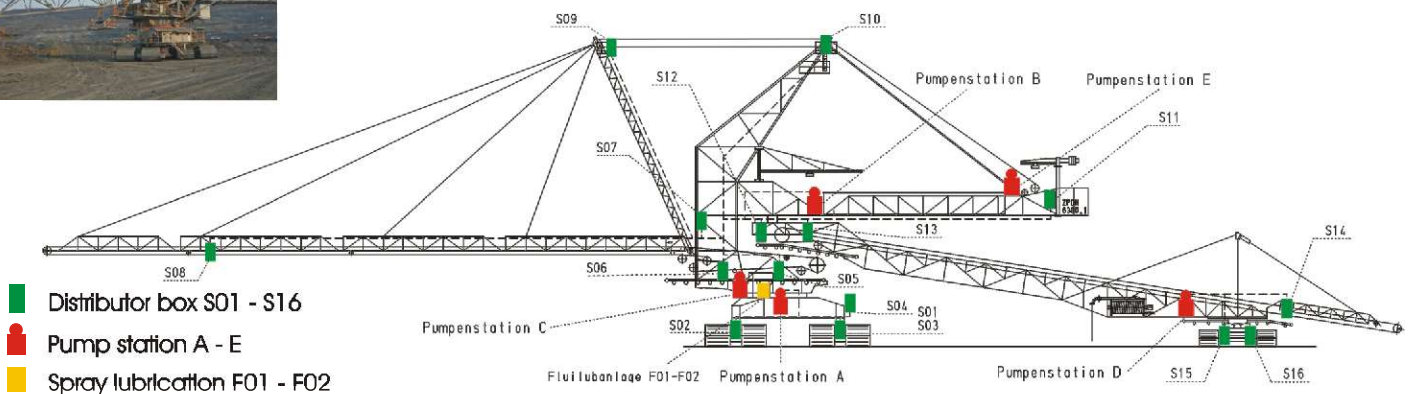

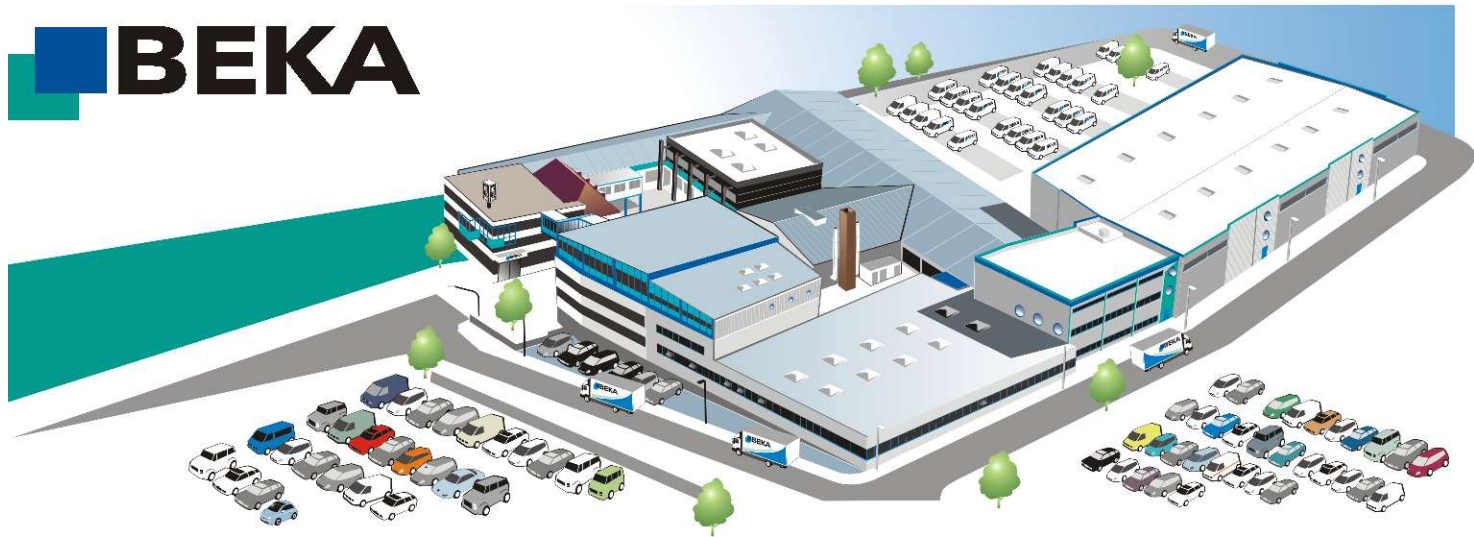

BAIER + KÖPPEL GMBH + CO KG
PRÄZISIONSAPPARATEFABRIK

BEETHOVENSTRASSE 14
91 257 PEGNITZ/BAVARIA

PO BOX 13 20
91 253 PEGNITZ/BAVARIA

GERMANY

fon +49 9241 729-0
fax +49 9241 729-00

e-mail beka@beka-lube.de
web www.beka-lube.de

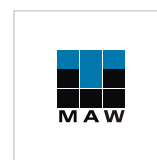
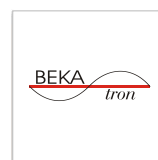
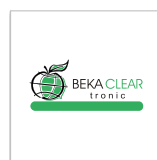
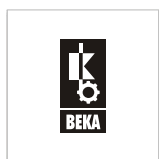

Partners

AUSTRIA

BEKA-Lube GmbH
Carola-Blome-Str. 7
5020 Salzburg
fon +43 662 43 84 40
fax +43 662 43 84 403
e-mail office@beka-lube.at

CHINA

EAST TSANHAIR COMPANY LTD.
7A Building, Medicine Valley No.1,
No.9 Tianfu Street, Bio-Medicine Park,
Zhongguancun Science Park,
Daxing District, Beijing, China 102600
fon +86 10 83 681 526
fax +86 10 83 681 520
e-mail beka-lube@bekachina.com

KOREA

BAIER + KÖPPEL Korea Liaison Office
A-1406, Sunyudo Woolim Lions Valley
Yangpyeong-dong 5-ga
Yeongdeungpo-gu, Seoul (150-984)
fon +82 2 2038 0988
fax +82 2 2038 8934
e-mail sales@bekaworld.kr

TURKEY

BEKAMAKS MAKINA SANAYI ve TICARET
LTD. STI, Kucukyali Ticaret Merkezi
B Blok No. 7 Girne Mah.
34852 Maltepe / Istanbul
fon +90 216 367 34 00
fax +90 216 367 33 85
e-mail info@bekamaks.com

BELGIUM

BEKA LUBE N.V.S.A.
Demerstraat 32
BE 3200 Aarschot
fon +32 16 64 09 26
fax +32 16 64 05 48
e-mail bekalube@skynet.be

FRANCE

BEKALUBE FRANCE
4, bis Rue de l'Artisanat
89100 Paron
fon +33 386 83 39 06
fax +33 386 65 52 24
e-mail contacts@bekalube.fr

NETHERLANDS

BEKA NEDERLAND B.V.
Wagenmakerij 11
4762 AV Zevenbergen
fon +31 168 37 15 38
fax +31 168 33 83 29
e-mail info@beka.nl

USA

BEKAWORLD LP
2775 North Hills Drive
Atlanta Georgia 30305 USA
fon +1 404 841 1133
fax +1 404 841 1196
cell +1 404 398 2165
e-mail s.pitman@bekaworld.co

CANADA

BEKA-LUBE Products Inc.
2830 Argenta Road, Unit 9
Mississauga ON L5N 8G4
fon +1 905 821 10 50
fax +1 905 858 05 97
e-mail info@beka-lube.com

ITALY

BEKALUBE s.r.l.
Via Rossi 152
20043 Arcore
fon +39 039 618 00 88
fax +39 039 61 75 23
e-mail bekalube@bekalube.it

SPAIN

BEKA-LUBE IBERICA S.L.
Avda. de Suiza, 3 P.A.L. Coslada
28820 Coslada (Madrid)
fon +34 91 670 78 00
fax +34 91 670 78 413
e-mail beka@beka-lube.es



Subsidiaries

Argentina	Great Britain	Latvia	Slovakia
Australia	Greece	Lithuania	Slovenia
Belarus	Hong Kong	Luxemburg	South Africa
Bosnia	Hungaria	Malaysia	Sweden
Brazil	India	New Zealand	Switzerland
Croatia	Indonesia	Norway	USA
Czechia	Iceland	Poland	and others
Denmark	Ireland	Portugal	
Estonia	Japan	Russia	
Finland	Korea	Serbia	